

Stressfree NG Maxi Freefall

Suitable for boats: 19.5ft – 40ft / 6 – 12m

Maximum boat weight: 5 tons

The Stressfree NG Maxi Freefall winch is strong, robust and super-fast, and has a patented freefall of up to 5 times faster than competing winches.

Product	Line Speed Max
NG Maxi Freefall	243 feet per min. / 74 meters per min.
Baseplate	Diameter Drum
0.31" / 8mm welded	11.81" / 300mm
Voltage	Gearbox
12v	63S
Motor power with High Torque	Emergency Manual Override
1400watt	√
Shaft size	Winch Weight
1.25" / 32mm	88.18lbs / 40kgs



The Stressfree NG Maxi Freefall anchor winch also features:

- Adaptable fit and varied mounting options, with the ability to reset the gearbox and motor assembly in 8 different configurations to best suit your anchor well
- Optional deck mounting
- One-touch precision anchoring for fast deployment and minimal drift to make anchoring a breeze
- All rope and chain is spooled on and off the drum
- Premium quality Italian motor and gearbox
- Waterproof 135amp circuit breaker with thermal overload cut-out
- 63 series gearbox
- 1400watt Motor with Cover, sealed with 5 meters of cable
- Solid stainless steel drive shaft
- Grease impregnated acetyl bush for superior performance
- Constructed from 316 L grade marine stainless steel
- Optional Pro-series guards upgrade
- Optional waterproof wireless remote
- 5-year warranty
- **Drum capacity options:**
 - o 85m of 10mm nylon spliced to 8m of 8mm short link chain
 - o 100m of 8mm double braid eye spliced to 5m of 10mm nylon spliced to 8m of 8mm short link chain

**Recommend dual batteries with the battery switch set to BOTH*

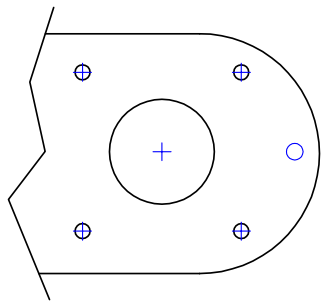
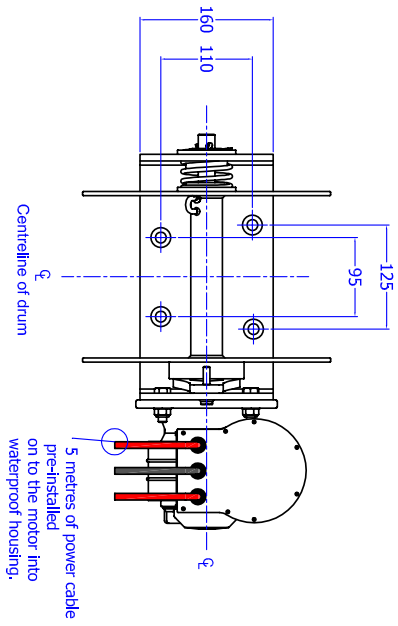

The gearbox mounting holes in the mounting bracket allow the motor and drive to be installed at 4 angles to suit different anchor well configurations. Another 8 minor angle adjustments are available between the gearbox and gearbox flange.

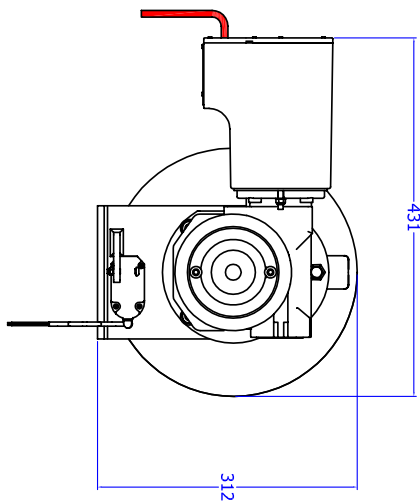
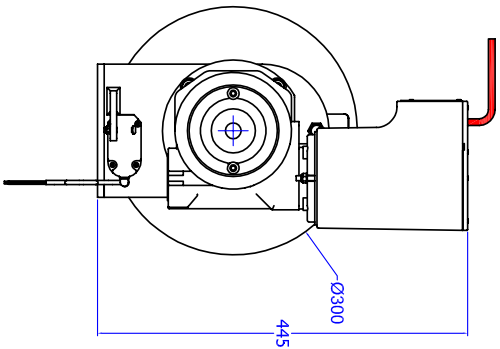
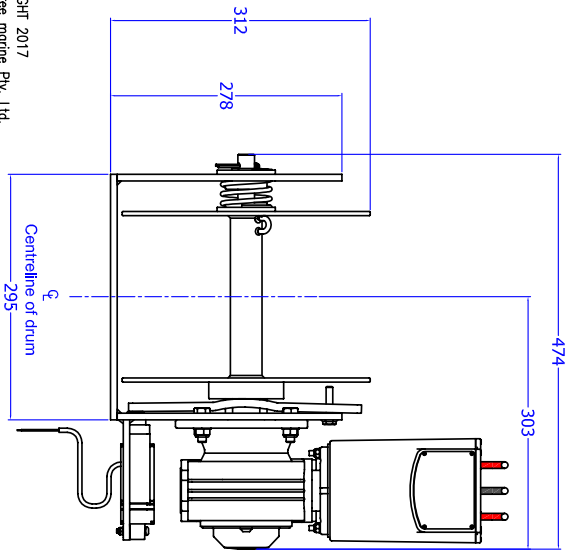
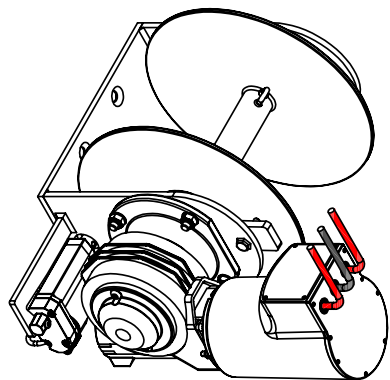

© COPYRIGHT 2017
Stressfree marine Pty. Ltd.

TOLERANCES		SCALE		MATERIAL		FINISH		DO NOT SCALE		DRAWING No.	
Unless otherwise stated		Drawn R/R		316 Stainless Steel		Linished		DIMENSIONS IN MILLIMETRES		UNLESS OTHERWISE STATED	
4	revision to add 5m cable and Motor Cover	18/4/17	NO DEC. ±	Checked		NAME					
3	revision to move motor vertical	28/4/15	1 DEC. PL. ±	Design OK		NG Maxi Freefall					
2	revision to remove Motor Cover	13/04/15	2 DEC. PL. ±	Approved							
Issue	Rev.	Drawn	Appr.	Date	ANGLES ±	DATE	23/08/08	stressfree marine Pty Ltd®		SF02100	