

# Stressfree Mini 50 Standard

**Suitable for boats:** up to 13.5ft – 26ft / 4-8m  
**Maximum boat weight:** 2.5 tons

The Mini 50 Standard winch is strong, robust and extremely fast.

Product	Line Speed Max
Mini 50 Standard	170 feet per min. / 52 meters per min.
Baseplate	Diameter Drum
0.31" / 8mm pressed	9.84" / 250mm
Voltage	Gearbox
12v	50S
Motor power with High Torque	Emergency Manual Override
500watt	√
Shaft size	Winch Weight
0.98" / 25mm	48.50lbs / 18kgs

## *The Mini 50 Standard anchor winch also features:*

- Adaptable fit and varied mounting options, with the ability to reset the gearbox and motor assembly in 8 different configurations to best suit your anchor well
- Optional deck mounting
- Premium quality Italian motor and gearbox
- Waterproof 80amp circuit breaker with thermal overload cut-out
- 50 series double anodised gearbox to prevent corrosion
- Solid stainless steel drive shaft
- Grease impregnated acetyl bush for superior performance
- Constructed from 316 L grade marine stainless steel
- All rope and chain is powered on and off the drum
- Optional Pro-series guards upgrade
- Optional waterproof wireless remote
- 5-year warranty
- **Drum capacity options:**
  - o 75m of 8mm nylon spliced to 6m of short link chain
  - o 100m of 6mm double braid eye spliced to 5m of 8mm nylon spliced to 6 meters of 6mm short link chain

*\*Recommend dual batteries with the battery switch set to BOTH*



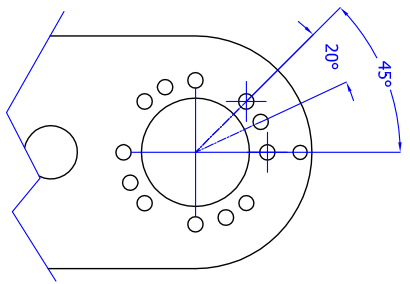
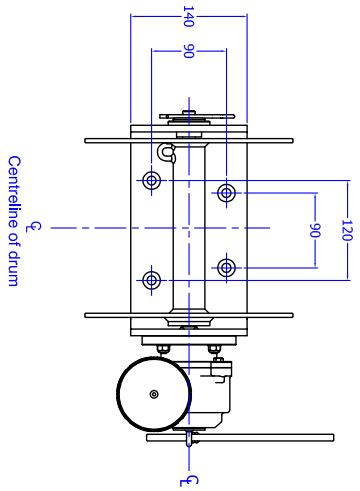

The gearbox mounting holes in the mounting bracket allow the motor and drive to be installed at 4 angles to suit different anchor well configurations. Another 8 adjustment angles are available at 20° and 45° from each of the basic 4 mounting holes.

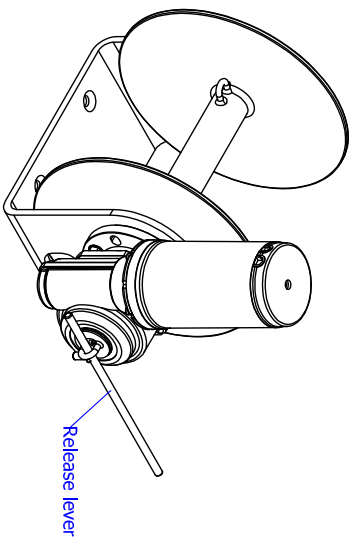

Note: the release lever is shown as it is included with the product but is only placed on the winch in emergency situations.

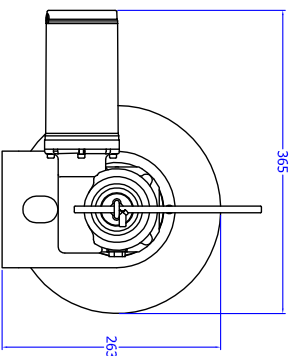
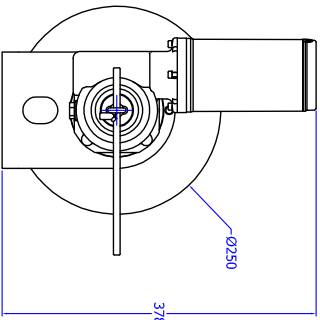
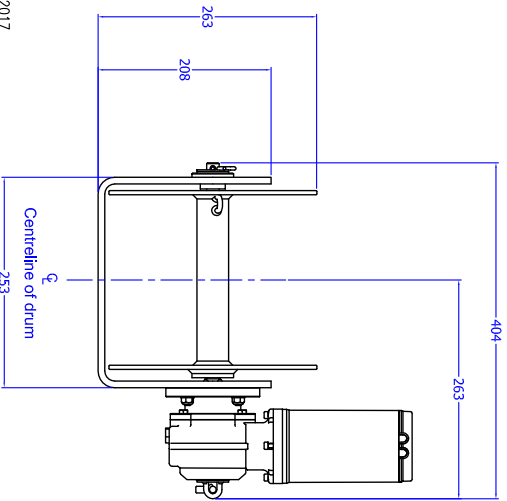

© COPYRIGHT 2017  
Stressfree Marine Pty.Ltd.

TOLERANCES		SCALE		MATERIAL		FINISH		DO NOT SCALE DIMENSIONS IN MILLIMETRES UNLESS OTHERWISE STATED		DRAWING No.	
Unless otherwise stated		Drawn	RJR	316 Stainless Steel		Satin				TBA	
3	revise to remove motor/gearbox adaptor	21.4.17	NO DEC. ±								
2	revise to show 8mm thick Mounting Plate	26.4.16	1 DEC. Pl. ±								
1	revise to show manual over ride.	17.4.15	2 DEC. Pl. ±								
Issue	Ref.	REVISION	Drawn	Apprv.	Date	ANGLES ±	DATE	2/05/08		NAME	
								stressfree marine Pty Ltd®		Mini 50 Standard	